

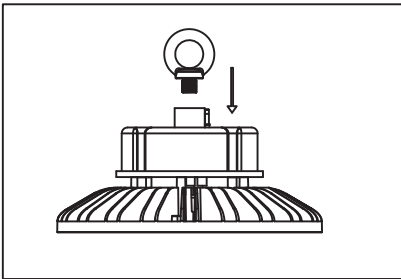

PLEASE READ ALL INSTRUCTIONS BEFORE ATTEMPTING INSTALLATION

- To prevent personal injury or product damage only licensed electricians should install.
- To avoid electric shock or component damage disconnect power before attempting installation or servicing.
- This product must be installed in accordance with the national electric code (NEC) and all applicable federal, state and local electric codes and safety standards.
- Disconnect product and allow cooling prior to servicing.
- Any alteration or modification of this product is expressly forbidden as it may cause serious personal injury, death, property damage and/or product malfunction.
- To prevent product malfunction and/or electrical shock this product must be properly grounded.
- This luminaire is designed to operate in ambient temperatures ranging from -30° c to 40° c and to be horizontally mounted with the LEDs facing down.
- UFO high bay only.

LOOP MOUNT



1. The suspension ring is assembled on the lamp body and the side anti-loosening screw is tightened.

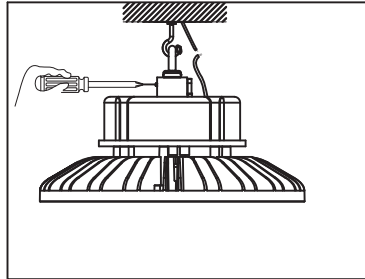

2. Hang the lamp hook on the lamp hook.

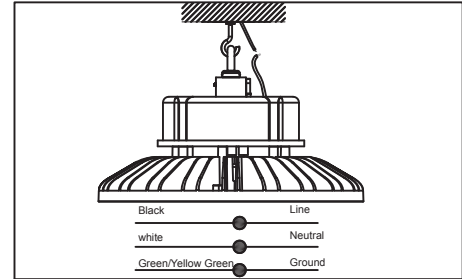

3. Connect the three wires (L: Black N: White G: Green) with the correct cable as shown in the figure.

TRUNNION MOUNT

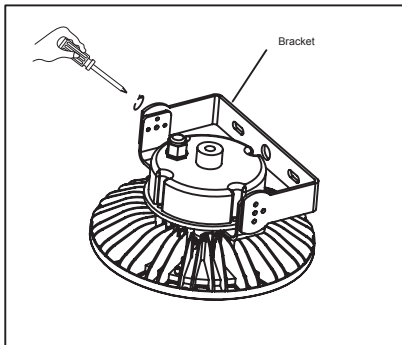

1. Use tools to screw out the screws at both ends of the bracket. (as shown in the figure)

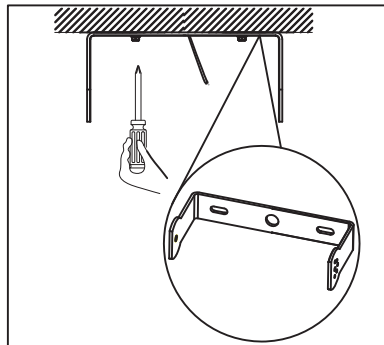

2. The bracket is fixed to the ceiling with two screws. (as shown in the figure)

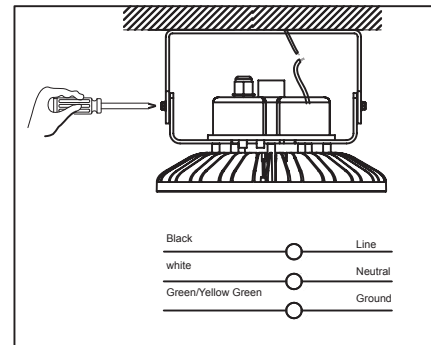

3. Adjust UFO fixture to correct position, fasten the screw. Connect to AC wire.

Aluminum Reflector Assembly Drawing

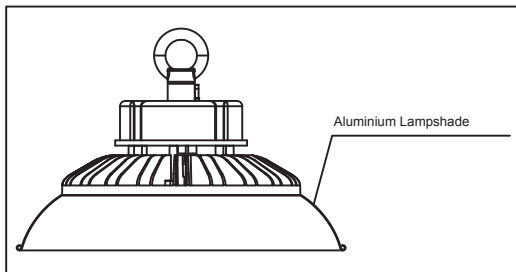

Microwave Installation Instructions

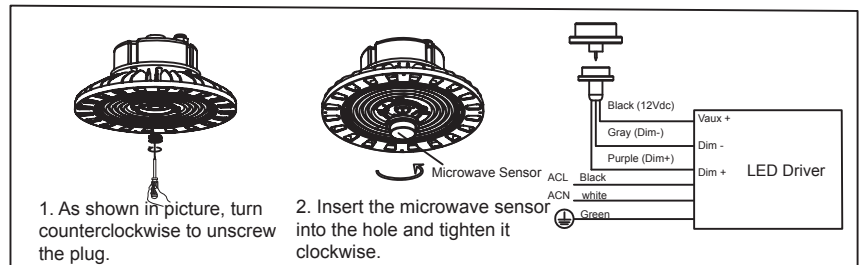

Note: Dimming wire is connected to sensor receptacle. Please ask an electrician to disconnect the dimming wires if they need to be used for other purposes.