



# HORIZONTAL MINI LED STEP LIGHT



## PRODUCT DESCRIPTION

3W LED step/wall lights are available in a horizontal configuration for mounting into a Junction box. For poured concrete and masonry installations. For indoor and protected outdoor use.

## ELECTRICAL SYSTEM

- Input voltage: 120V
- 50/60Hz
- Power Factor: >0.87
- Working Temperature: -13-95°F (-25-35°C)

## SPECIFICATION

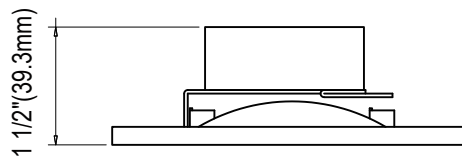
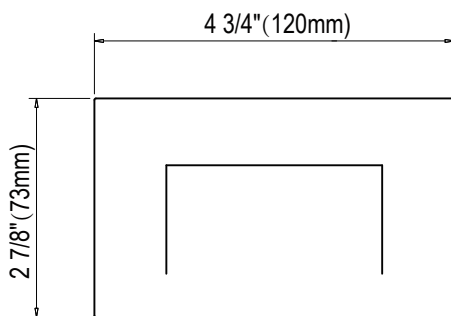

## PERFORMANCE

CRI

**80**

CCT

**3000K**

Dimming

**Non dimming**

Projected Lifetime

**L70 -100,000 Hours**

Working Temperature

**-13-95°F (-25-35°C)**

Certifications

- ETL Listed
- Suitable for wet locations
- RoHs compliant

## Ordering Information

Example: HMSL03304-BK

Model	Watts	CCT	Voltage	Control	Finish
HMSL	03 - 03W	30 - 3000K	4 -120	Blank - None	BK - Black

Notice:

- \* Minimum order required, please contact customer service for additional information.
- \* Black finish is standard. Custom color is available for a premium setup fee. Consult customer service for additional information.

## PHOTOMETRY

All published luminaire photo metric testing performed to IESNA LM-79-08 standards by a NVLAP certified laboratory.

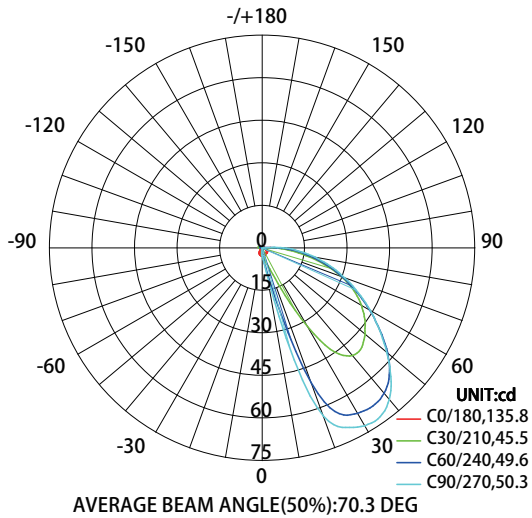

## PERFORMANCE DATA

### LUMEN OUTPUT

Lumen values are measured by third party certified laboratories performed in accordance with IESNA LM-79-08 as well as Lighting Facts listed.

Watts	Lumen Output	AC Input 120V	CCT	CRI
3	100	0.09A	3000K	80

### BUG Rating

Performed to IESNA LM-79-08 standards by a NVLAP accredited laboratory.

Model	BUG Rating
HMSL03304	B0-U1-G0

## Warranty

Two year limited warranty. Full warranty terms located at [www.abovealllighting.com/warrantystatements](http://www.abovealllighting.com/warrantystatements)

## Note:

Specifications subject to change without notice.