



Ref No. 10301-211125



LED PARKING GARAGE FIXTURES

(Version 101)



ABOVE ALL Lighting, Inc.

 1501 Industrial Way N. Toms River, NJ 08755

 866-222-8866

 info@abovealllighting.com

 www.AboveAllLighting.com

©2020 ABOVE ALL all rights reserved

LS Garage Light



- Around 11% uplight
- Superior Low-glare Illumination
- Performance up to 136LPW
- Sensor and EBU available
- With junction box, Easy for surface or pendant mount.



LS Garage Light

11% uplight

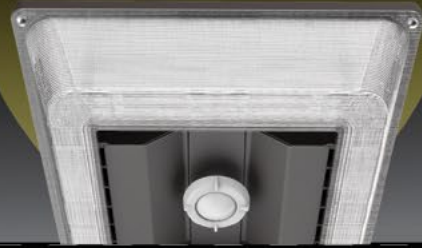

Superior low-glare illumination

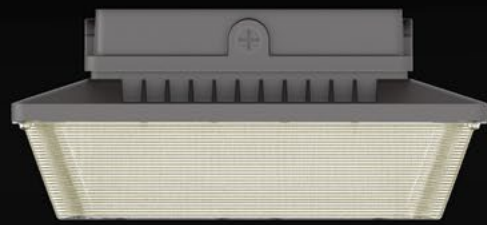
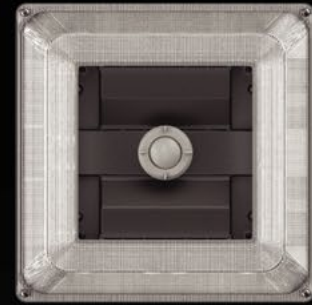

Performance up to **136 LPW**

With **junction box**,
easy for surface or pendant mount



Pendant Mount



Surface Mount



Trunnion Mount

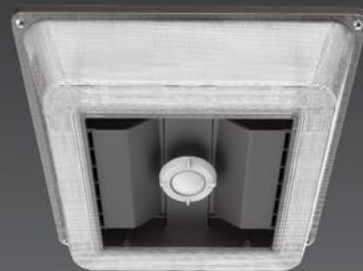

Sensor and **EBU** available

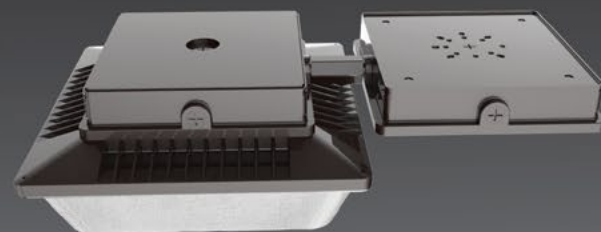

LED Moon Series Garage Light

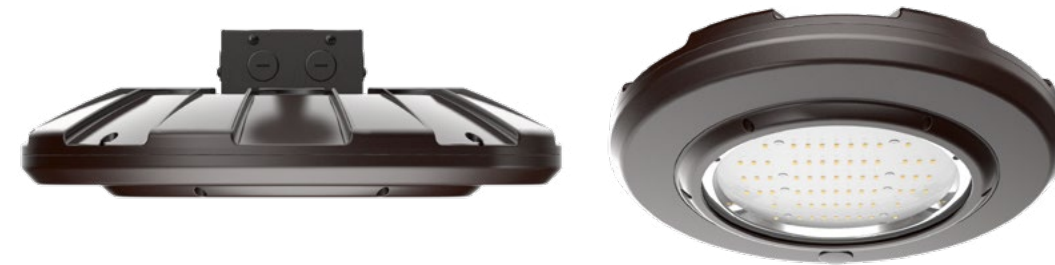

- Tempered Clear and frosted glass lens
- Various mounting options
- Programmable Multi-level
- Motion Sensor
- Performance up to 136LPW





LED Moon Series Garage Light

Tempered clear and frosted lens

Low Glare Design

Performance up to 136LPW



Programmable Multi-level Motion Sensor



Hook Mount



Pendant Mount



Surface Mount

LED Vapor Tight



- 6% Up-light to reduce cave effect
- NSF approved for splash and Non-food Zones
- IP66 rated for wet location
- 347V and EBU are available for 40W/4ft

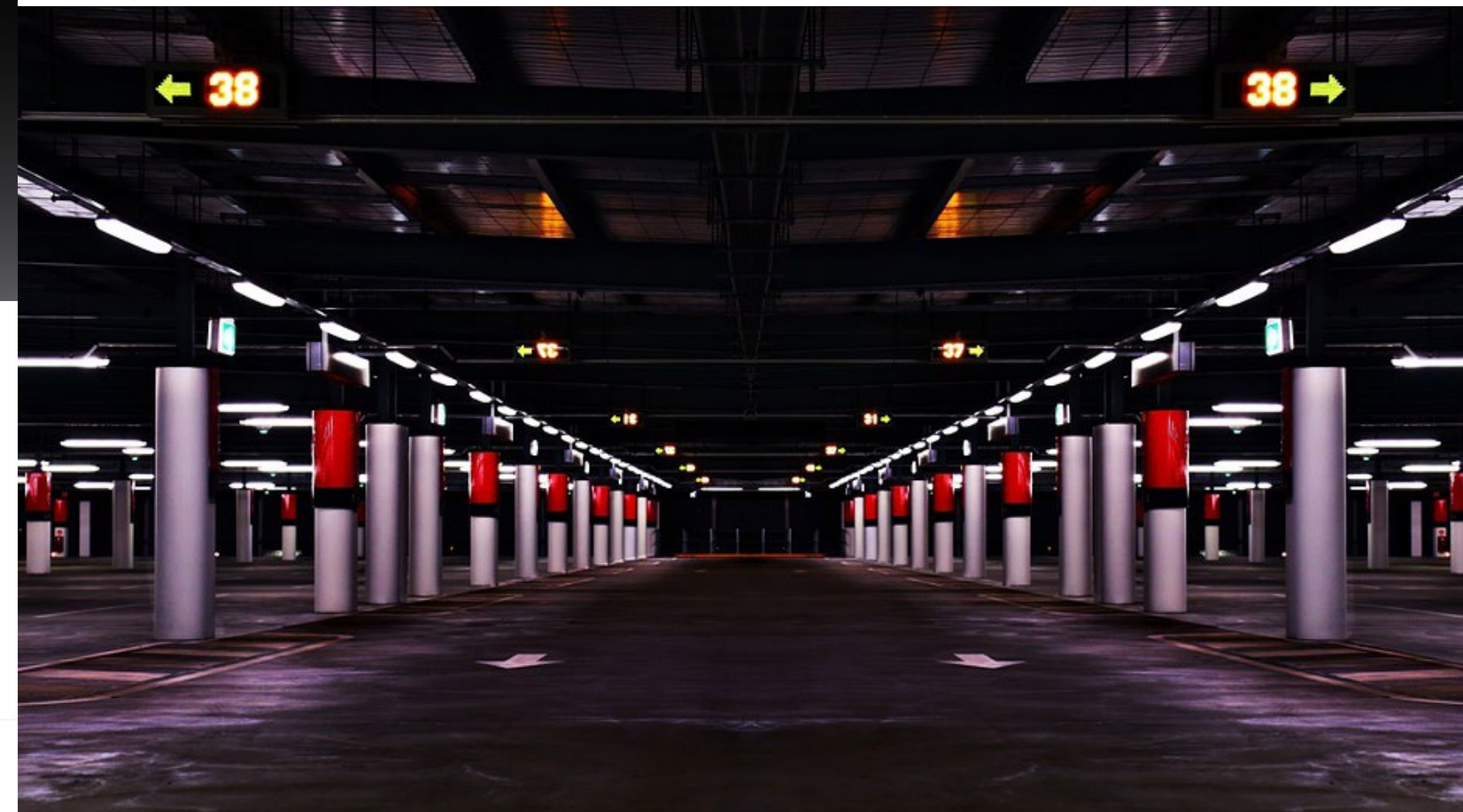

LED Vapor Tight

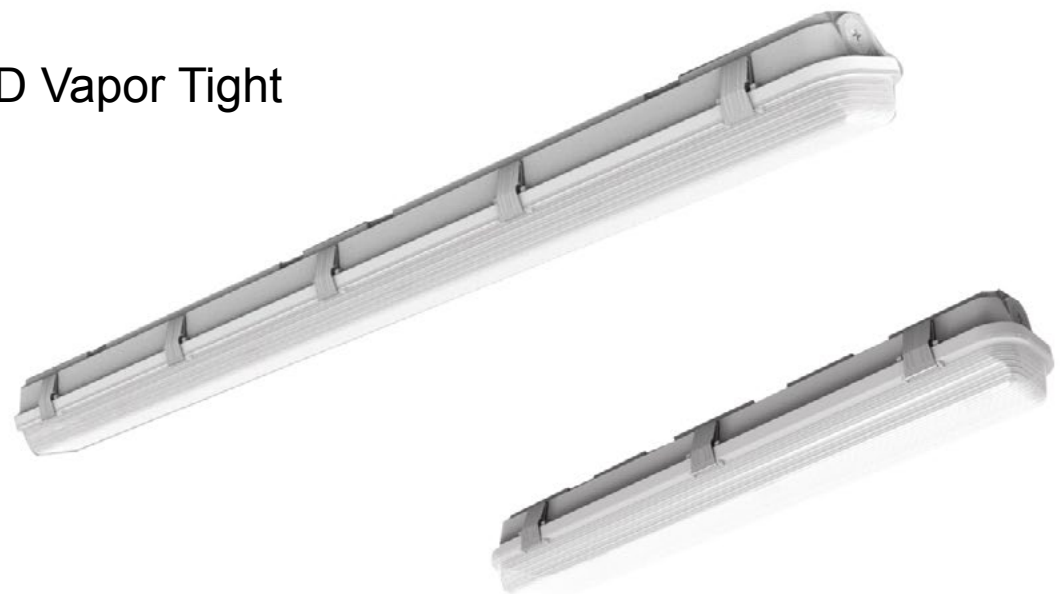

2ft Wire Cord **Easy To Wire;**
No Need To Open The Housing,
Easy To Install



IP 65 rated, against dust and water.



Vision LED Strip Light



- Around 8% up-light and no glare
- Quick and Easy to wire and install
- Continuous-run mount
- Seamless connection
- Built-in sensor
- EBU backup available
- Philips driver is used for 2ft,3ft and 4ft

