

SUITABLE FOR MODEL

MODEL: FHSAC1-UNV-40L

**SAFETY INSTRUCTION**

READ CAREFULLY BEFORE INSTALLING FIXTURE. PLEASE KEEP THIS MANUAL FOR FUTURE USING.

Fixtures must be wired in accordance with the National Electrical Code and all applicable local codes. Proper grounding is required for safety.

THIS PRODUCT MUST BE INSTALLED IN ACCORDANCE WITH THE APPLICATION CODE BY A PERSON FAMILIAR WITH THE CONSTRUCTION AND OPERATION OF THE PRODUCT AND THE HAZARDS INVOLVED. MAKE CERTAIN POWER OFF BEFORE INSTALLING OR MAINTAINING FIXTURE.

CHECK THAT VOLTAGE IS COMPATIBLE WITH FIXTURE DRIVER, USE APPROVED CONNECTORS FOR ALL ELECTRICAL CONNECTIONS.

RISK OF FIRE OR ELECTRIC SHOCK. MAKE SURE POWER SUPPLY IS OFF BEFORE INSTALLING OR MAINTAINING THE PRODUCT.

RISK OF FIRE OR ELECTRIC SHOCK. INSTALL THIS PRODUCT ONLY IN THE LUMINAIRES THAT HAVE THE CONSTRUCTION FEATURES AND DIMENSIONS SHOWN IN THE PHOTOGRAPHS AND/OR DRAWINGS AND WHERE THE INPUT RATING OF THE PRODUCT DOES NOT EXCEED THE INPUT RATING OF THE LUMINAIRE.

RISK OF FIRE OR ELECTRIC SHOCK. TO PREVENT WIRING DAMAGE OR ABRASION, DO NOT EXPOSE WIRING TO EDGES OF SHEET METAL OR OTHER SHARP OBJECTS.

RISK OF FIRE OR ELECTRIC SHOCK. LED RETROFIT KIT INSTALLATION REQUIRES KNOWLEDGE OF LUMINAIRE ELECTRICAL SYSTEMS. IF NOT QUALIFIED, DO NOT ATTEMPT INSTALLATION. CONTACT A QUALIFIED ELECTRICIAN.

RISK OF FIRE OR ELECTRIC SHOCK. ONLY THOSE OPEN HOLES INDICATED IN THE PHOTOGRAPHS AND/OR DRAWINGS MAY BE MADE OR ALTERED AS A RESULT OF KIT INSTALLATION. DO NOT MAKE OR ALTER ANY OPEN HOLES IN AN ENCLOSURE OF WIRING OR ELECTRICAL COMPONENTS DURING INSTALLATION.

RISK OF FIRE OR ELECTRIC SHOCK. NEVER PERFORM MAINTENANCE OR CLEANING WHILE FIXTURE IS ENERGIZED. DISCONNECT POWER AND ALLOW FIXTURE TO COOL BEFORE MAINTAINING.

RISK OF INJURY. WEAR SAFETY GLASSES AND GLOVES DURING INSTALLATION AND SERVICING.

MAINTENANCE CAUTION

1. Review the wire connection before beginning, and make sure fixture is grounded properly.
2. For lighting controls, using functioning correctly.
3. Turn power off and wait for fixture cooling to operate.
4. Maintenance must be done by professionals.
5. This unit has more than one power supply connection point.

To reduce the risk of electric shock, disconnect the brand circuit-breakers or fuses and emergency power supply unit before servicing.

SAVE THESE INSTRUCTIONS

When using electrical equipment and this lighting device basic safety precaution should be followed at all times including but not limited to the following:

PLEASE READ CAREFULLY AND FOLLOW ALL INSTRUCTIONS FOR YOUR OWN SAFETY

- IMPORTANT:** An un-switched AC power source of 120VAC to 277VAC is required for the yellow/black and white leads.
- IMPORTANT:** A switched or un-switched AC power source of 120VAC to 277VAC is acceptable for the black lead only.
- This device is designed for use in fixtures listed for **dry and damp locations**
- CAUTION:** Make sure all electrical connections conform to the National Electrical Code and all applicable local regulations.
- CAUTION:** Do not let power supply cords touch hot surfaces.
- CAUTION:** Do not mount near gas or electric heaters.
- CAUTION:** Do not use this emergency driver with accessory equipment other than recommended by manufacturer; failure to follow this may cause an unsafe condition. Servicing should only be performed by qualified service personnel.
- CAUTION:** Do not use this emergency driver for other than intended use.
- CAUTION:** Battery is rechargeable LiFePO4 type and must be recycled or disposed of properly.
- CAUTION:** Equipment should be mounted in locations and at heights where it will not readily be subjected to tampering by unauthorized personnel.

ASSEMBLY and FIELD INSTALLATION WIRING: WARNING: AC power must be off before proceeding with assembly, installation or servicing of emergency driver. Additionally ensure that the battery is disconnected (Battery Switch set to OFF).

TESTING SYSTEM: The emergency battery requires a minimum charge time of one (1) hour before testing the circuit. A minimum of twelve (12) hours is required for a full charge.

RATED EMERGENCY OPERATION: Ninety (90) minutes for the 10W load or one hundred eighty (180) minutes for the 5W load. The 10W or 5W option is determined by the position of Dip Switch 1 (Emergency Power Selection Switch).

FOR THE LED EMERGENCY DRIVER

PLEASE READ CAREFULLY AND FOLLOW ALL INSTRUCTIONS FOR YOUR OWN SAFETY

SELF DIAGNOSTIC INSTRUCTIONS / OPERATION:

If Dip Switch 2 (Self-Diagnostic Switch) is set to the OFF position:
A functionality test shall be manually conducted by pressing the test switch for thirty (30) seconds every thirty (30) days to ensure the emergency LED light source illuminates as intended. A full discharge test shall be conducted once a year; the LED light source shall illuminate for a minimum of ninety (90) minutes for the 10W load or one hundred eighty (180) minutes for 5W load.

If Dip Switch 2 (Self-Diagnostic Switch) is set to the ON position:
The self diagnostic feature is set. The self diagnostic cycle is activated by pressing the test switch three (3) times. Once the self diagnostic is activated, the emergency LED driver will conduct a self check for thirty (30) minutes every thirty (30) days; and ninety (90) minutes or one hundred eighty (180) minutes self check every 12 months. After every self check the LED indicator light will indicate a status signal. Refer to table 1 for details.

TABLE 1 - Self Diagnostic Indications	
LED Indicator Status Signal	Description of Status Signal
0.5s ON and 0.5s OFF	Battery disconnected.
2.5s ON and 2.5s OFF	LED load disconnected.
4.5s ON and 0.5s OFF	Driver in self-diagnostic mode.
1.5s ON and 3.5s OFF	Battery needs to be replaced.
0.5s ON and 4.5s OFF	Damaged driver. Needs to be replaced.
ON	Normal/Charging.
OFF (With LED Load ON)	Discharging / Emergency Operation.

SAVE THESE INSTRUCTIONS

WIRE CONNECTION

An AC power source of 100VAC to 277VAC is required

1. An un-switched AC power source of 120VAC to 277VAC is required for the **YELLOW/BLACK** and **WHITE(N)** leads.
2. A switched or un-switched AC power source of 120VAC to 277VAC is acceptable for the **BLACK(L)** lead only.
3. Connect the **GROUND** leads on fixture and driver to **GROUND** supply lead.

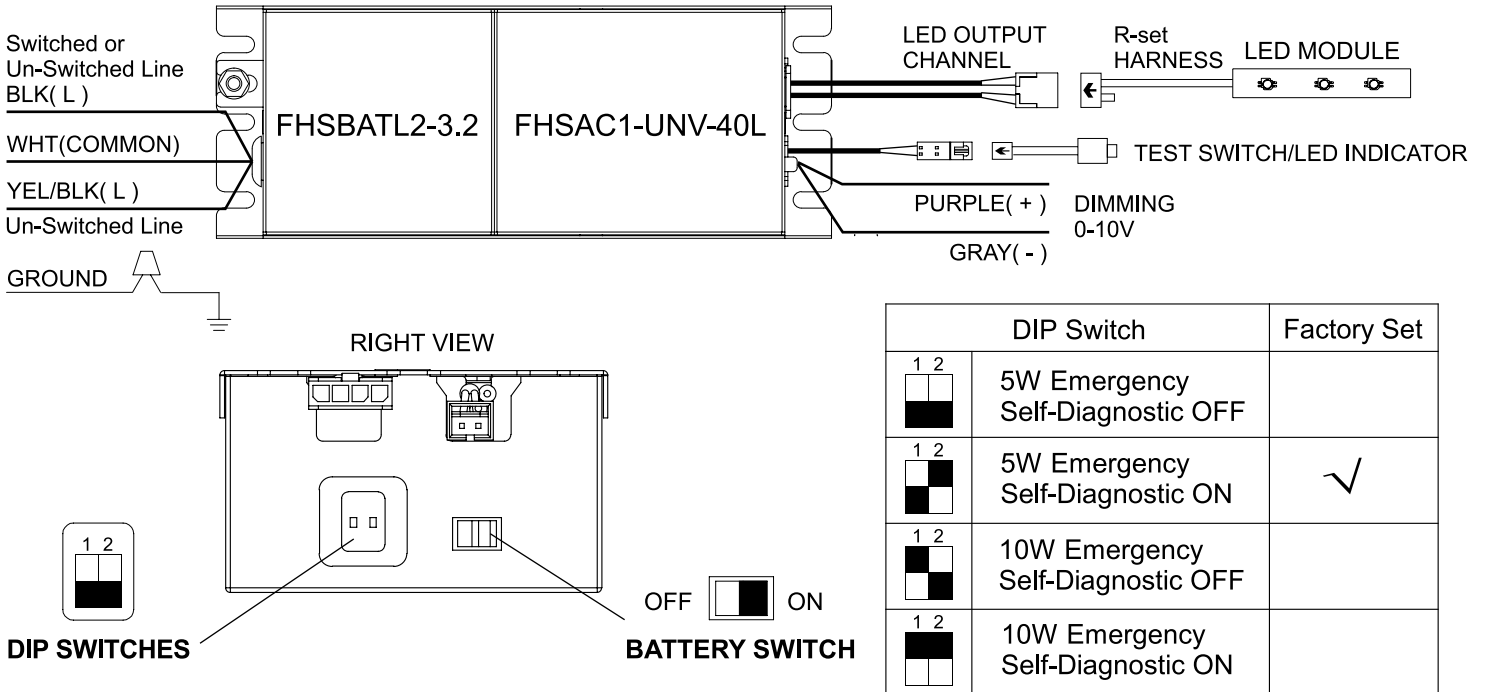

NOTE:

1. The driver must be grounded.
2. Once assembly, installation or servicing is complete, set the BATTERY SWITCH to the ON position.

INSTALLATION

RECESSED CEILING MOUNT

1. Rotate and place the fixture into the ceiling grid.
2. Bend the grid clip (4) against the ceiling grid to secure the fixture.
3. Bend the support wire clip. Make support wires (supplied by others) get through support wire hole.
4. Make sure that the orientation of access plate faces an accessible tile to make electrical splices.
5. Remove the access plate by taking off the screw. Knock out the conduit knockouts to make input conduit to get through.
6. Connect wires according to wiring diagram. Push all wires back into the splice box. Be careful not to pinch wires.
7. Put the access plate back by tightening the screw.

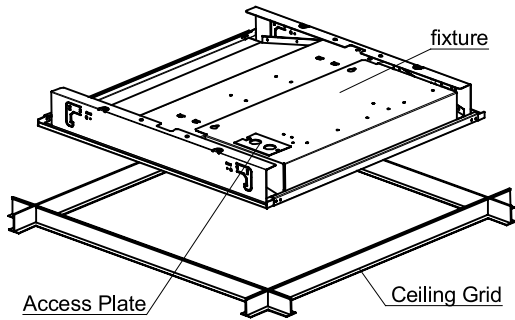

fig.1

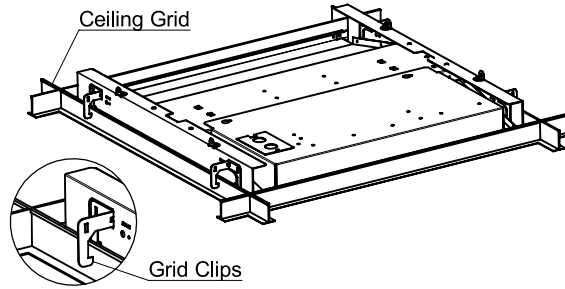

fig.2

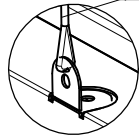
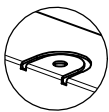
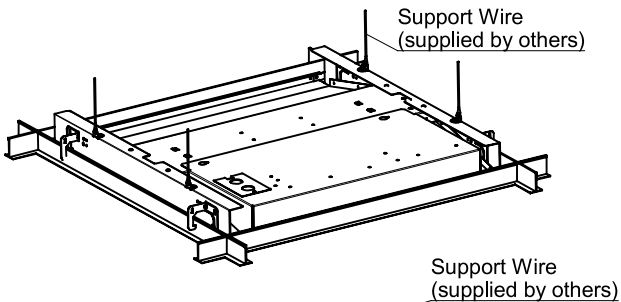

fig.3

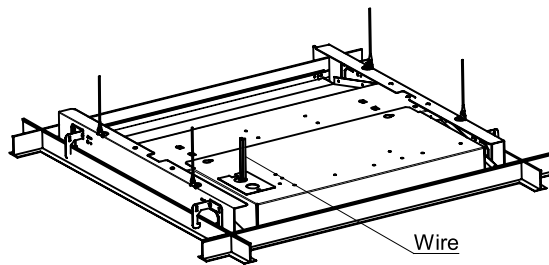

fig.4

FCC NOTICE

CAUTION: Changes or modifications not expressly approved could void your authority to use equipment. This device complies with part 15 of the FCC Rules. Operation is subject to the following two conditions: (1) This device may not cause harmful interference, and (2) this device must accept any interference received, including interference that may cause undesired operation.

This equipment has been tested and found to comply with the limits for a Class A digital device, pursuant to part 15 of the FCC Rules. These limits are designed to provide reasonable protection against harmful interference when the equipment is operated in a commercial environment. This equipment generates, uses, and can radiate radio frequency energy and, if not installed and used in accordance with the instruction manual, may cause harmful interference to radio communications. Operation of this equipment in a residential area is likely to cause harmful interference in which case the user will be required to correct the interference at his own expense.

CAN ICES-003 (A)/NMB-003 (A)